

**inter.noise 2000**

The 29th International Congress and Exhibition on Noise Control Engineering  
27-30 August 2000, Nice, FRANCE

---

I-INCE Classification: 7.2

## MEASUREMENT SYSTEM UPGRADING FOR MORE PRECISE MEASURING OF THE HEAD-RELATED TRANSFER FUNCTIONS

G. Wersényi\*,\*\*

\* Technical University of Budapest, Stoczek u.2., 1111, Budapest, Hungary

\*\* Szechenyi Istvan College, Hedervari u. 3., 9026, Gyor, Hungary

Tel.: (+36) 1 463 19 36 / Fax: (+36) 1 463 17 63 / Email: wersenyi@sparc.core.hu

**Keywords:**

HRTF, SNR, MEASUREMENT, SETUP

**ABSTRACT**

A well controlled system is the basis of any precise acoustic measurement. A computer and DSP card-based system was installed in the anechoic room to measure the Head-Related Transfer Functions. This system and the measuring software were upgraded using the conclusions of a previous investigation. We present some methods to get a higher SNR and a flexible, easily modifiable and comprehensive system with reproducible precision. We will show how to get an average SNR about 89 dB and how to get precise HRTF's from all directions. These could be useful for hearing investigations and virtual reality, for creating helpful tools for blind people (e.g. "acoustical mouse"), and for further investigations on the field of discrepancies in the acoustical information transmission.

**1 - INTRODUCTION**

The principal part is the perception of the physical sound-waves. In this signal processing system the outer ears and the head play a significant role. The ears have different filter characteristics depending on the angle of incidence. The transfer functions in the head-related coordinate-system (HRTF) contain and describe their behavior [1].

In a former measurement we collected the different HRTF's from all directions. The evaluation of the results showed some insufficient parts of the measurement system [2]. Several parts remained unchanged but some aspects had to be upgraded to get increased precision and SNR.

This system is used to investigate the problems of the spatial hearing e.g. the imperfections of the dummy-head recording systems [3], [4], [5]. Our goal is to improve the whole measurement system and verify its capability. It is important to make extensive use of this setup in many other fields of audio and acoustic measurements (research, education, standardization, etc.)

**2 - FORMER RESULTS**

**An earlier investigation**

The earlier investigation used a Brüel & Kjaer 4128 head and torso simulator placed on a Brüel & Kjaer 3921 turntable in the anechoic room. The horizontal plane step was 5°, the elevation varied from -15° up to +90° in 5° or 10° steps [2]. The DSP card was an AT&T DSP card in a standard PC. The measuring signal was a periodical pseudo-random noise. This noise is calculated specifically for this setup, and it is close to the noise of the unloaded system. Using this kind of noise-excitation we get a frequency-independent SNR. This signal was calculated by a tool program, which requires the averaged powerspectra of the whole system. This can be calculated from the answers given to the zero excitation. The noise signal will be repeated and the answers averaged to increase the SNR. We do not measure during the first period of excitation to avoid the effect of the suddenly appearing input (step-answer). As pseudo-random signals are *deterministic* signals, every time we double the number of the periods of the excitation we will get a +3 dB increase in the SNR.

For the proper setting of the elevation of the loudspeaker we put a *laser targeting system* onto the head of the torso. This beam reaches a mirror placed on the loudspeaker and it will be reflected on the body of the torso. If the place and the orientation of the loudspeaker are correct, the reflected spot is in the median plane at a given distance in the head-related coordinate-system. The laser targeting system has to be calibrated carefully before, and it will be removed during the measurement. All the data needed for this setting is calculated by another tool program. The loudspeaker is 2 metres away and adjustable by strings. There are also reflections-absorbing materials on crucial places.

From the measured HRTF's and from the calculated Head-Related Impulse Response (HRIR) functions we concluded to the proper and insufficient parts of the system as shown in Table 1 [2].

<b>Parts and methods which were appropriate</b>	<b>Parts and methods to modify and revise</b>
no measurement in the first period of the input signal (against step-answer appearing)	the 5° step turning of the table is not enough (horizontal plane measurement)
repeated measurements and averaging to avoid random noise effects	the precision and the reproducibility of the stopping positions of the turntable
82 msec. period pseudo-random noise input signal	extension of the elevation under -15°
a precise laser-beam direction calibrator for precise elevation determination	more flexible, and comprehensive measurement software
2 channel, 16 bit resolution, 50 kHz sampling frequency	Reduction of the mains (220 V) disturbing effect

**Table 1:** Summary of the satisfactory and non-satisfactory elements of the earlier measurement.

### 3 - NOVEL METHODS

#### Methods

As shown in Table 1, there are more aspects to upgrade. The first was to replace the old synchronous motor with a stepping motor which can be controlled more precisely. It makes 32000 steps until the turntable makes only one turn. Because the best resolution of the hearing of a human being does not exceed 1° [1] we made the new measurement with this resolution. This can be set with a precision of 1,14%. The motor is controlled by a software through the serial port of the PC.

The loudspeaker and the setting method stayed the same, but to get results from the domain -45° to -15° of elevation we had to place the torso higher on the turntable.

With the writing of a new measuring and plotting software we created a full-equipped measurement system. This program controls the turntable, delivers the input signal for the loudspeaker, collects the responses from both ear-microphones, calculates their 2 channel 4096 points complex FFT and the transfer function (HRTF) and finally stores it on the hard disk. The drawer program delivers the figures with lots of plotting functions. We also need the laser beam reflection calculating program mentioned above.

#### The measurement

For the measurement used reference signal was recorded using a 1/2" Brüel & Kjaer microphone type 4165 in the origo of the head-related coordinate system (without the torso). This unidirectional microphone was placed on the turntable vertically. The spectra of the answer it delivered were used as the reference signal. The complex HRTF is given by the quotient of the spectra of the answer through the torso and the spectra of the reference signal above. That way we can avoid all the undesired transfer functions in the transmission line (amplifiers, cable, loudspeaker etc.). The only information remaining is the difference between the unidirectional microphone and the microphone of the torso with the artificial pinna.

The measurement system is able to reduce the disturbing effect of the mains periodicity (50 Hz, 100 Hz etc.). We repeat the measurement in 24 different position of the mains phase (Fig. 2). It means 24 times more measurement time but distinct improvement (Fig. 3) at the main frequencies.

Finally we measure in every one step 32\*24=768 period. This is an additional +29 dB improvement in the SNR. On average, the number of the used bits in the entire measurement is 10 bits, which gives a 60 dB dynamic range and SNR. All in one the averaged SNR is about 89 dB. This needs 1 minute of measurement time in every position, and 7 hrs. for turning 360°. The maximal increase of the SNR is limited by the memory of the DSP card, but it is not worth using +42 dB of increase because of the gratuitously increasing measurement time.

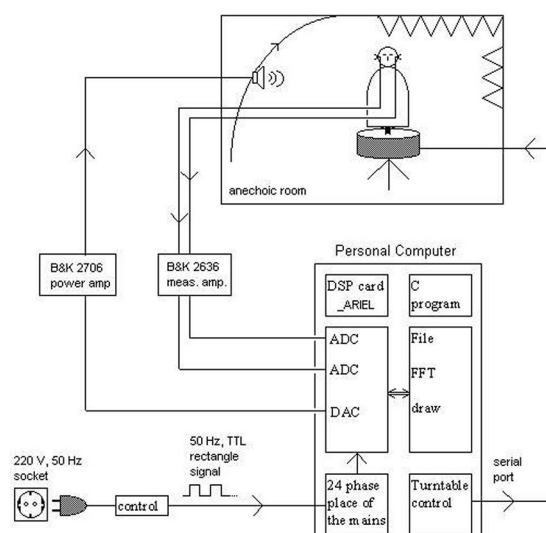

**Figure 1:** The measurement setup.

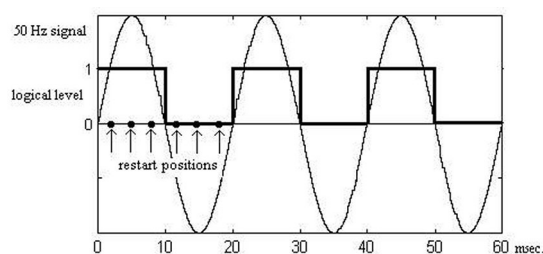

**Figure 2:** Restart positions of the measurement in connection with the mains periodicity; this figure shows the partition for 6 different position instead of 24; the measurement is not in connection with the mains periodicity (phase).

#### 4 - SUMMARY

In the end we can say that the most inappropriate parts were upgraded and we are able to measure with an average SNR of 89 dB during a reasonable measurement time. With the replacing of the motor we got a more precise and reproducible movement of the turntable. With the refinement of the horizontal step an increased resolution of the HRTF's is achieved. The directions under  $-15^\circ$  are now also measurable. The differences now appearing in the results in progress of time were probably caused by variation of the reflections or generated by the amplifiers.

#### REFERENCES

1. **Blauert, J.**, *Spatial Hearing*, MIT Press Cambridge, 1983
2. **Berényi, P., Illényi, A.**, What does it mean for an HRTF not to have the minimal phase property?, In *Inter Noise 96*, pp. 2127-2130, 1996
3. **Moller, H., Sorensen, M.F., Hammershoi, D., Jensen, C.B.**, Head-Related Transfer Functions of human subjects, *J. Audio Eng. Soc. (AES)*, Vol. 43, pp. 300-321, 1995
4. **Moller, H.**, On the quality of artificial head recording systems, In *Inter Noise 97*, pp. 1139-1142, 1997
5. **Illényi, A., Wersényi, Gy.**, Discrepancy in binaural tests and in measurements of sound field parameters, In *International Békésy Centenary Conference on hearing and related sciences Budapest*, pp. 160-165, 1999

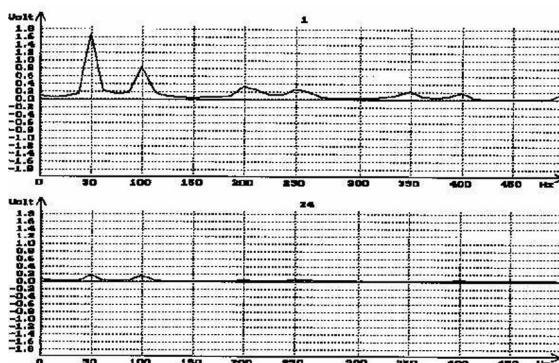

**Figure 3:** Reduction of the mains disturbing effect; the upper figure shows the spectra of the 50 Hz rectangle test signal; using the reduction system (24 different positions) we get a significant decrease of the amplitudes.

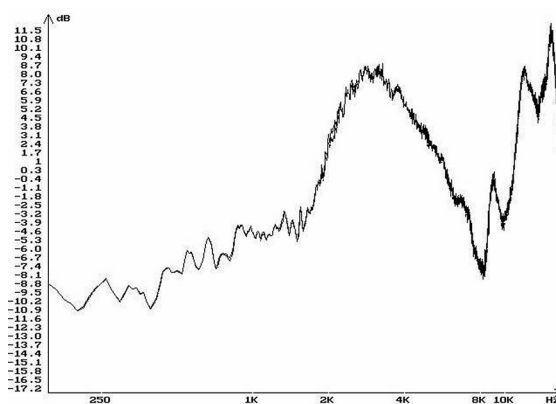

**Figure 4:** Two HRTF measurements at front incidence after displacing and setting back the source direction  $\delta = \varphi = 0^\circ$ ; there is no noticeable difference, which confirms the reproducibility of this setup.