

NON DESTRUCTIVE EVALUATION OF MATERIALS PROPERTIES BY ULTRASOUNDS

A.Badidi Bouda^a, R. Halimi, M. Benzohra, A. Benchaala & S. Lebaili^b

Laboratoire de Caractérisation et d'Instrumentation, Centre de Soudage et de Contrôle, Algiers, ALGERIA Tél.
& Fax. : 213 21 36 18 50,

(^b) Laboratoire Génie des matériaux, Faculté des sciences de l'ingénieur, Département Génie Mécanique,
USTHB BP 32 El Alia, Bab Ezzouar, 16111 Algiers, Algeria
Email: alibadidi@yahoo.fr

Abstract: In this article we describe experimental studies based on the measurement of some ultrasonic parameters through various samples. The obtained results showed that one can determine quantitatively and / or qualitatively mechanical and physical characteristics of some materials.

Introduction:

The acoustic waves crossing a material come out from it modified. These modifications are dependent on the mechanical or structural aspect of the explored matter. This article describes the experimental work which relate the relation between some ultrasonic parameters and the mechanical and physical materials characteristics.

Velocities and attenuation of ultrasonic waves in polycrystalline materials

In the Rayleigh region, we have two opposing phenomena (i.e. upward shift due to scattering and downward shift caused by attenuation). However the sound path length z is high, the downward shift is preponderant, and the velocity decreases. The down shift frequency decreases α whereas the increase in mean grain size diameter makes increase α_s .

Ultrasonic measurements

Velocities are measured from the wave times of flight in the sample thickness. For the attenuations, the amplitudes of the three first back-wall echoes are measured to compute the attenuation coefficients of the L and T waves.

The probe displacement, in a water tank, is performed by two step by step engines. The numerical scope allows a sampling and storage in microcomputer memory for processing.

Determination of the heat affected zone width (HAZ) in welding.

The sample is a rectangular carbon steel plate. A fusion was caused by a manual process on its two edges. We have measured the L wave attenuation evolution through the 2 HAZ.

Analyze results:

The attenuation coefficient curves begin by a maximum then decrease regularly to stabilize at a given distance which corresponds to the attenuation of the healthy metal and thus delimits the HAZ width. The obtained results show that the HAZ obtained by ultrasounds is confirmed by the macrographic test carried out for comparison.

Determination of the 2nd elastic constants of materials

The principle is based on the velocities measurement of two propagation modes through the samples. From each material (carbon steel, stainless steel and copper), we have taken samples for the tensile tests. The experimental results obtained by the two methods (ultrasonic and destructive) have given the same results with a variation of about 3% except for the Poisson ratio of carbon steel.

Determination of the third elastic constants of metallic materials

To find out these constants, we have conceived an experimental device which is composed of a tank filled with water connected to a tensile testing machine. Two probes were used in transmission (fig. 1). This device allows to change the incidence angle, with two goniometers.

We have characterized many materials. As an example we give the results for the E36W steel. Velocities measurements in the planes $P_{//}$ and P_{\perp} were taken [1]. The 3rd elastic constants calculated are given in table 1 and show an agreement with other authors works [2].

Characterization of the steel hardness

The hardness is the material resistance to a local penetration. The thermal processing principle consists in heating the sample and then watering it on one side.

Hardness measurements

The hardness (fig.2) is highest on the cooled face side then decreases to stabilize at 35 mm which corresponds to the hardness before processing

Ultrasonic measurements

The measured ultrasonic parameters are V_L, V_T, α_L and α_T along the sample. As an example we give the L wave attenuation coefficient curve (fig. 3). We can deduce that it is possible to assess the hardness by measuring V_L [3].

Characterization of the steel grains size

The metallographic analysis of E24steel samples showed that only the grains size have changed. The grains size (fig. 4) is weaker on the cooled face side and increases to stabilize at a distance which is the material grain size before processing.

Ultrasonic measurements

The measured ultrasonic parameters are: V_L , V_T , α_L and α_T . The V_L curve (fig. 5) starts with a maximum and decrease until a value of 40mm to stabilize at a constant value This curve compared to the one giving the average grains diameter, show an opposite effect on the cooled face side[4].

Conclusion

This study showed that it is possible quantitatively to characterize with an acceptable accuracy the 2nd and 3rd elastic constants of metallic materials as well as the HAZ width of a welded joint. The evolution analysis of the ultrasonic parameters and the hardness and grains size curves of steel shows the possibility to assess to these characteristics by the simple measurement of the velocity or the attenuation coefficient of one propagation mode. The results obtained are compared with those obtained by traditional techniques and literature and showed a good agreement. This work opens the way with the development of quantitative and / or qualitative non destructive characterization techniques of materials by ultrasounds.

References

- [1] M. Bentahar, & al, second and third order elastic constants determination of an isotropic solid, 15th WCNDT, Roma, October 2000
- [2] V. Hauk And Al. Structural And Residual Analysis By Non Destructive Methods . Elsevier. 1997
- [3] A. Badidi Bouda, & al , Ultrasonic characterization of materials hardness, Ultrasonic (38), 2000, 224-227
- [4] A. Badidi Bouda & al, Grain Size Influence On Ultrasonic Velocities and Attenuation », NDT&E International Elsevier, volume 36, number 1, pp1-5 , January 2003

		v_1 (GPa)	v_2 (GPa)	v_3 (GPa)
Our results		-98 ±7	-240 ±12	-163 ±9
literature results	Wasserbach	-96	-254	-181
	Schneider	-134	-261	-167

Table 1. Third elastic constants of E36 W steel

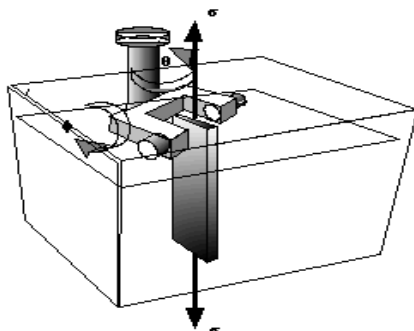

Fig. 1 experimental device

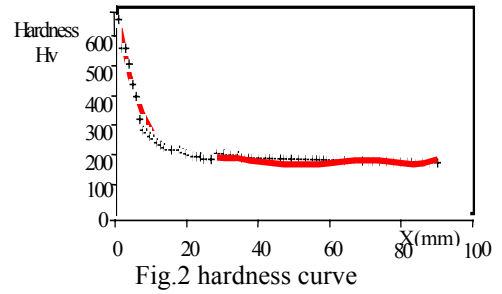

Fig.2 hardness curve

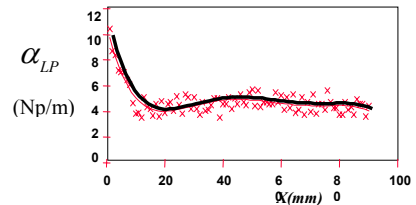

Fig.3 L wave attenuation coefficient

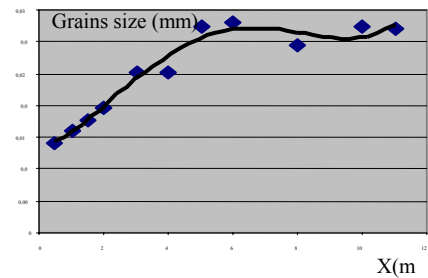

Fig.4 grain size curve

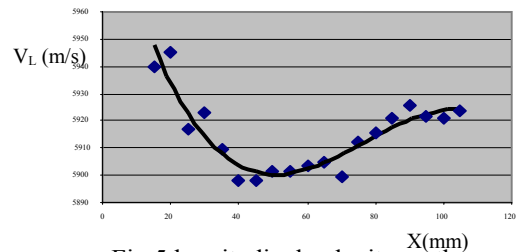

Fig.5 longitudinal velocity on the