

# Control of Pipe Flow Resistance by Sound

Matthias Jüschke, Dirk Ronneberger

III. Phys. Institut, Universität Göttingen, Bürgerstr. 42-44, 37073 Göttingen, Email: m.jueschke@dpi.physik.uni-goettingen.de

## Introduction

Passive sound damping in ducts is often accomplished by resonators formed as side-branches to the duct. Also cascades of resonators are used. With superimposed mean flow through the duct the effect of such mufflers may change dramatically. Self-excited oscillations and amplification of sound may occur. Due to conservation of energy, the generation of sound necessarily effects the mean pressure drop through the duct section lined with resonators. We study the possible use of this effect for the control of the mean flow. Fig. 1 shows one of the tested resonator configurations which are part of an otherwise rigid walled duct.

Besides a high ratio between the induced pressure drop and the controlling sound amplitude we are interested in avoiding the radiation of the amplified controlling sound into the leading and, particularly, the trailing duct. Therefore we study the effects of higher order modes which are evanescent in the rigid walled duct.

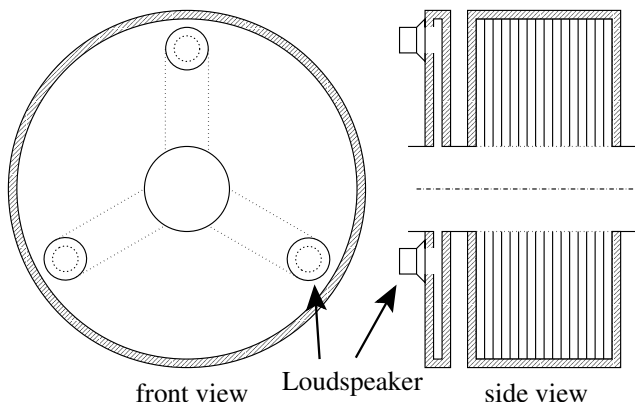

Figure 1: Yielding-walled pipe section

In previous studies axisymmetric resonators have been investigated [1]. The flow-induced amplification of the fundamental mode is restricted to a range of frequencies slightly above the frequency of the first radial resonance of the narrow chambers. This is, by the way, the frequency range where the damping is most effective when the air is at rest. The highest sound amplification and the highest pressure drop are observed with deep narrow chambers. In our studies, the depth and the width of the most effective chambers is 75 mm and 5 mm respectively. The first radial symmetric resonance is at  $f_0 = 850$  Hz, while the first azimuthal resonance is at 1000 Hz. 16 of these chambers are assembled in a series, and this configuration has also been used in the following experiments; the inner diameter of both the rigid and the yielding pipe sections is 50 mm. Generally, the amplification of the controlling sound increases when the mean flow velocity  $u$  is increased.

## Experiments

Three loudspeakers have been mounted around the circumference of the pipe immediately upstream the lined duct section in order to radiate the controlling sound into the pipe. Three different modes were excited: a plane mode (the loudspeakers are driven at equal amplitudes and phases), a spinning mode that is evanescent in the rigid pipe (phase differences of  $120^\circ$  between the loudspeakers), and the superposition of the two contrarotating spinning modes. In this latter case only two loudspeakers were driven at equal amplitudes and opposite phases. For each of these modes the sound induced pressure drop across the yielding duct section has been measured and has been normalised to the dynamic pressure of the mean flow. The blue  $\circ$  curve in Fig. 2 shows the pressure drop for the plane mode. This reproduces earlier results [2] except for the strong interference caused by the sound wave which is reflected from the inlet of the leading rigid pipe (length ca. 4 m).

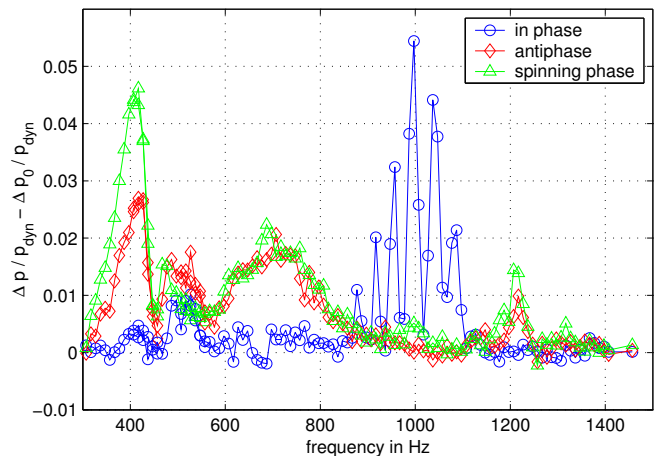
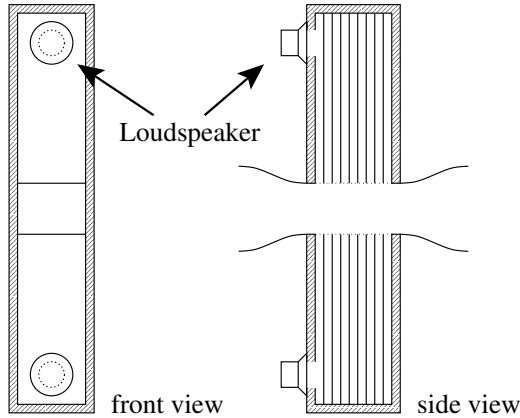

Figure 2: change of pressure drop depending on incident sound for the pipe section with  $u = 69$  m/s.  $\circ$  fundamental,  $\diamond$  antisymmetric and  $\triangle$  spinning mode

The red  $\diamond$  and the green  $\triangle$  curves show the pressure drop for the azimuthal modes without any interference since these modes do not propagate through the rigid pipe. The close similarity between these two curves was expected since the dynamics of the respective modes is identical except for nonlinear effects. Surprisingly, however, these curves are completely different from the blue  $\circ$  curve for the plane mode. The highest pressure drop is found at a very low frequency (400 Hz) which is small compared to the azimuthal resonance frequency. Another low-frequency range with a clear influence on the pressure drop evolves between 600 and 800 Hz. The physics behind these low-frequency effects is not yet understood.

As a working hypothesis we assume that an un-

stable aeroacoustic mode is excited by the controlling sound, and that this mode—like the Kelvin-Helmholtz instability—draws its energy from the concentration of vorticity in the shear layer at the interface between the resonators and the flow duct. So we were presuming that the considered interaction between the mean flow and the resonant wall could be intensified by a further concentration of the vorticity, i. e. by making the boundary layer thinner. It was also presumed that the circular geometry should not be essential.



**Figure 3:** Yielding-walled duct section with accelerated flow

Thus the yielding section of the flow duct was reconstructed to have a rectangular  $3 \times 4 \text{ cm}^2$  cross-section (Fig. 3) which has a smaller area than the rigid pipe and therefore leads to an acceleration of the mean flow including a decrease of the boundary layer thickness. Smooth fittings were inserted between the rigid pipe and the rectangular test section to realise gradual transitions between the different cross-sections and to keep the flow as smooth as possible. The two opposite broad sides of the rectangular duct are lined with resonators ( $f_0 = 850 \text{ Hz}$ ) as shown on Fig. 3. Two loudspeakers, one on each side, are coupled to the resonator chambers at the inlet of the yielding duct section which in total consisted of nine pairs of chambers in the case discussed below.

Fig. 4 shows the sound induced pressure drop for the symmetric and the antisymmetric controlling mode. No whatsoever similarity between the results for the circular and the rectangular test section is found (compare Fig. 4 and Fig. 2). The superimposed sound only lowers the pressure drop in the rectangular duct with a maximum effect at about  $1800 \text{ Hz}$  for  $u = 69 \text{ m/s}$  and  $800 \text{ Hz}$  for  $u = 93 \text{ m/s}$ .

Several reasons may be responsible for the differences between the two resonator configurations. First of all, the mean flow may separate in the trailing diffusor-like fitting behind the rectangular duct section. Thus a separation bubble is formed which causes an additional pressure loss depending on the extent of the separation bubble. It has been shown, that the extent of such bubbles and the associated pressure loss can be considerably reduced by superimposed flow oscillations.

Secondly, a zoo of strong self-excited pressure oscillations are encountered in the experiments with the rectangular test section, probably due to the high Mach num-

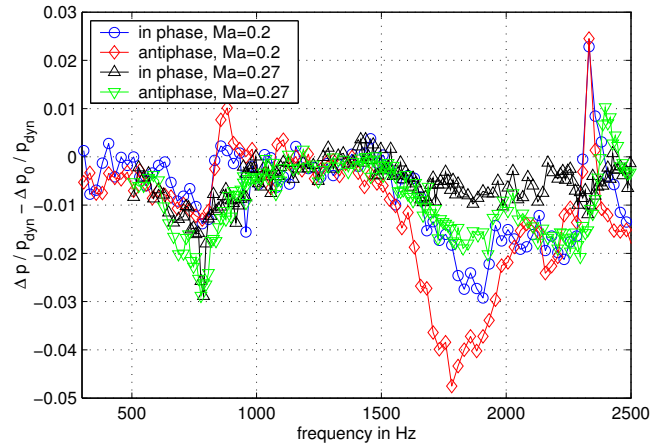

**Figure 4:** Change of pressure drop depending on incident sound for the rectangular duct section.  $\circ$  fundamental and  $\diamond$  antisymmetric mode for  $u = 69 \text{ m/s}$ ,  $\triangle$  and  $\nabla$  for  $u = 93 \text{ m/s}$  respectively.

ber and the thin boundary layer in the rectangular duct. Some nonlinear interaction between the self-excited and the weaker superimposed sound oscillation might occur leading to a modified dependency of the pressure drop on the amplitude of the controlling sound.

Last but not least theoretical calculations [3] have shown that the mode spectrum, that is excited by the controlling sound in the lined flow duct, depends on the wavenumber differences between all these modes. Small differences can lead to large amplitudes of the respective modes. In fact, the amplitude of the most unstable mode in the circular duct was dominated by an exceptionally small such difference, according to the considered model of the duct, and this small difference was absent in the mode spectrum of the rectangular duct. This might also explain why no sound amplification comparable with the circular duct was found with the rectangular duct.

We can conclude from these experimental results, that the aeroacoustic plane wave sound amplification by a sequence of radial symmetric resonators and the controllability of the pressure drop cannot be simply extrapolated neither to other modes of excitation nor to other geometries. So one is tempted to further conclude that the circular geometry with the plane wave excitation is somewhat of a singular case.

## References

- [1] M. Brandes: Schallverstärkung in Strömungskanälen mit resonanzartiger Wandauskleidung, Dissertation, Göttingen (1997)
- [2] B. Lange, D. Ronneberger: Active Noise Control by Use of an Aeroacoustic Instability, Acta Acustica united with Acustica **89**, 658-665
- [3] J. Großer: Modellbildung für die Schallverstärkung in nachgiebig ausgekleideten Strömungskanälen, Dissertation, Göttingen (2003)