

Power transmission coefficients for generic structural junctions

Ennes Sarradj

Gesellschaft für Akustikforschung Dresden mbH, D-01099 Dresden, Germany, Email: ennes.sarradj@akustikforschung.de

Introduction

A number of numerical methods such as statistical energy analysis, energy finite element method and smooth energy methods exist for the prediction of high-frequency structure-borne sound. In all these methods, the transmission across structural junctions is characterised by power transmission coefficients. Thus, the results of the calculation depends on the exact prediction of these coefficients. "Simple" formulas[2] are often not sufficient, especially for complex junctions. The finite element method may solve the problem, but only at the cost of a large computational overhead. Below, a generic approach[1] for the calculation of power transmission coefficients is presented.

Generic approach

The approach taken is presented here on the basis of an electro-mechanical analogy for reasons of simplicity and clarity. Consider a junction of N electrical wave guides (Fig. 1), defined by their wave admittance \underline{G} . A wave incident to the junction on wave guide m has an associated current i_{mi} . Kirchhoffs theorem states that the sum of this current and that of the transmitted waves i_{nt} must vanish:

$$\sum i_{nt} = -i_{mi} \quad (1)$$

The reformulation using the admittances of the wave guides and the voltage u_{mi} of the incident wave yields an equation

$$\sum G_n u_c = 2G_m u_{mi}, \quad (2)$$

which can be solved for the junction voltage u_c . It is then straightforward to calculate the transmission coefficients τ_{mn} as ratio of the powers carried by the transmitted and

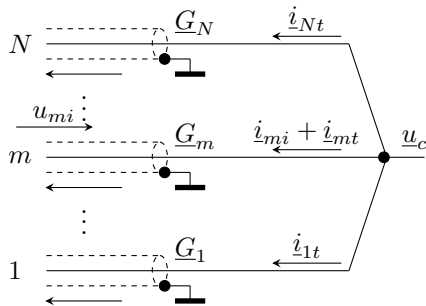

Figure 1: A junction of electrical waveguides

the incident wave:

$$\tau_{mn} = \frac{\frac{1}{2} \text{Re} (u_c^* G_n u_c)}{\frac{1}{2} \text{Re} (u_{mi}^* G_m u_{mi})}, \quad n \neq m. \quad (3)$$

For $m = n$, u_c has to be replaced by $u_c - u_{mi}$.

This approach can be extended for multiple degrees of freedom (DOF) and wave guides in the three-dimensional space. To this end, the analogy relations $i \leftrightarrow \underline{F}$, $u \leftrightarrow \underline{v}$, $\underline{G} \leftrightarrow \underline{Z}$ have to be applied first. Then, scalar quantities have to be replaced by vector quantities, e.g. $v \leftrightarrow \underline{v}$, that account for multiple DOFs. Finally, to incorporate the three dimensions, a co-ordinate transformation to global co-ordinates by matrix \mathbf{K} has to be used. Equation (2) reads then:

$$\sum (\mathbf{K} \underline{\mathbf{Z}}_n \mathbf{K}^T) \underline{v}_c = 2 \text{diag} (\underline{\mathbf{Z}}_m) \underline{v}_{mi,wt} \quad (4)$$

This system of equations has as many unknowns as DOF are considered and must be solved for the vector of junction velocities.

A mechanical wave guide may bear different types of waves, e.g. bending, compression and shear waves. Therefore, instead of u_{mi} the vector of incident wave velocities $\underline{v}_{mi,wt}$ has to be applied, which is different for each wave type.

The approach in equation (4) is sufficient for the calculation of transmission coefficients for a point junction of beams. For a line junction of plates or shells, it must be further extended[4]. In this case, the wave guides are two-dimensional and a wave can impinge from different angles. Each of this angles θ of incidence corresponds to a trace wave number $k = k_0 \cos \theta$ at the junction. If the DOFs at the junction are treated as functions of k , for each angle of incidence a transmission coefficient may be

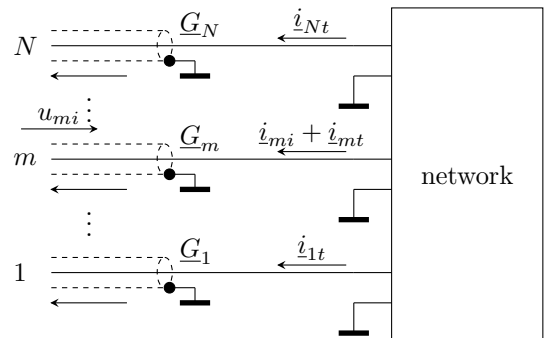

Figure 2: Same as Fig. 1, but with the junction represented by a network



Figure 3: A line junction with I-Beam, plate: steel, 2 mm, beam flanges: steel, 4 mm, beam dimensions: 10 cm x 15 cm

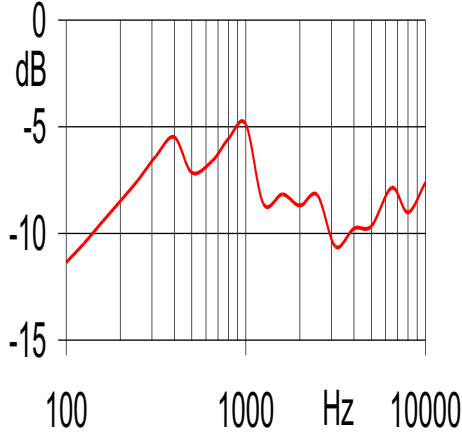

Figure 4: Bending wave transmission coefficient for the junction in Fig. 3 plotted over frequency

computed. Integration over all angles of incidence yields the diffuse field transmission coefficient:

$$\bar{\tau} = \int_0^{\pi/2} \tau(\theta) \sin \theta d\theta. \quad (5)$$

In practice, this calculation needs to be carried out numerically.

A further possible extension of the approach is to account for a lumped element at the junction, e.g. a point mass or a coupling beam at a line junction. This is done by adding the impedance matrix of that element to the sum of impedances on the left side of (4). In the same way a more complicated junction type may be treated. If the junction is not a single point or line but consists of a network (Fig. 2), the cross impedance matrix $\underline{\mathbf{Z}}_c$ for that network can be added:

$$\underline{\mathbf{Z}}_c + \left[\sum (\mathbf{K}\underline{\mathbf{Z}}_n\mathbf{K}^T) \right] \underline{\mathbf{v}}_c = (0 \dots 2\underline{\mathbf{Z}}_m \underline{\mathbf{v}}_{mi} \dots 0)^T. \quad (6)$$

In this case the number of unknowns increases to incorporate all DOFs at all ports of the network and $[\dots]$ is a matrix with the sums of the wave impedances for the appropriate network ports as diagonal sub-matrices.

A last extension of the approach is concerned with point to line junctions. As shown elsewhere[3], the point impedance of a line junction may be calculated by integrating over an appropriate wave number spectrum. The same may be done for the calculation of transmission coefficients. The calculation procedure is then very similar to that for the line junction, but the numerical integration must be carried out over the $(-\infty, \infty)$ interval.

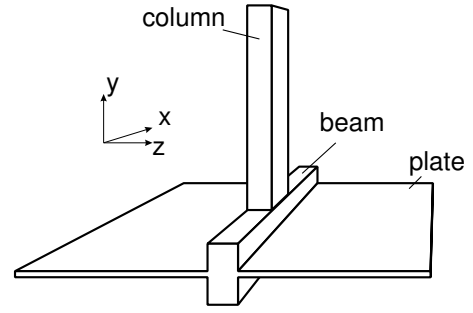

Figure 5: Line junction with column: steel, plate: 2 mm, column and beam: 10 mm x 20 mm

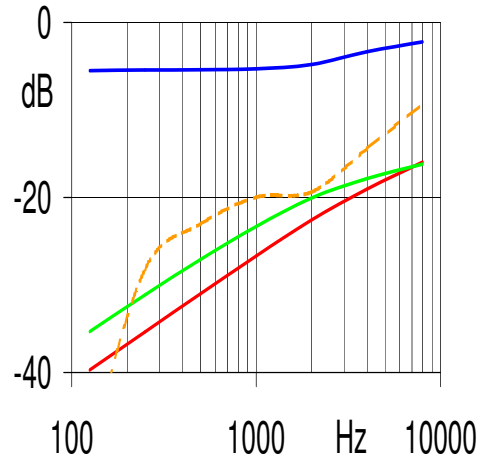

Figure 6: Example result for the junction in Fig. 5: incident x-bending wave on column to plate compression (red), shear (orange) and bending (blue) waves and to all waves in beam (green)

Summary

A generic approach for the calculation of power transmission coefficients was presented. Included in this approach are several types of connections: line-connected plates, point-connected beams, point-connected-plates and point connections between beams and line-connected plates.

References

- [1] E. Sarradj: Hochfrequenter Körperschall in Strukturen. Dissertation, TU Dresden, 1998
URL: <http://www.freesea.de>
- [2] L. Cremer, M. Heckl: Körperschall. 2nd edition, Springer, Berlin, 1996.
- [3] E. Sarradj: Calculation of point mobilities at generic multi-plate/beam junctions. J. Sound Vib. **229**(2), (2000), 411-431
- [4] R. Langley, K. Heron: Elastic wave transmission trough plate/beam junctions. J. Sound Vib. **143**(2), (1990), 241-253