



**Acoustics'08
Paris**
June 29-July 4, 2008

www.acoustics08-paris.org

A new impedance tube for large frequency band measurement of absorbing materials

Jean Christophe Le Roux^a, Jean-Pierre Dalmont^b and Bruno Gazengel^b

^aCTTM, 20, rue Thales de Milet, 72000 Le Mans, France

^bLaboratoire d'Acoustique de l'Université du Maine, Avenue Olivier Messiaen, 72085 Le
Mans, France

jcлерoux@cttm-lemans.com

The standard two microphones technique does not allow the measurement of absorbing materials characteristics at low frequency. Moreover, to cover a range from 100 to 6000 Hz two experiments have to be done with two different sample diameters. By using a sensor with a known volume velocity source developed by the LAUM together with the CTTM, it is demonstrated that the impedance can be obtained from 10 to 5000 Hz by performing only one measurement with a single material sample. Results showing the behaviour of some materials at low frequency are presented. On the other hand a comparison is done with the classical two-microphone impedance tube method.

1 Introduction

In the present paper a new impedance measurement setup is presented. It was first designed for the measurement of the input impedance of musical wind instruments in the frequency range 20-4000 Hz. It is used here to measure the absorption coefficient of absorbing materials

2 Principle

The impedance measurement setup proposed uses a piezo-electric buzzer as a source. This buzzer is fixed on its back to a closed cavity and is connected to the front to the measured pipe (see figure(1)). The pressure p_2 at the input of the pipe is measured by a microphone (mic 2) and a second microphone (mic 1) measures the pressure p_1 in the back cavity, this pressure being at first order proportional to the flow U delivered by the source. The impedance $Z = p_2 / U$ is thus at first order proportional to the transfer function between the two microphones. At first order, it can be written:

$$\frac{p_1}{p_2} = -jC\omega Z \quad (1)$$

where $C = \frac{V}{\rho c^2}$ is the acoustic compliance of the

back cavity of volume V , with ρ the air density and c the speed of sound.

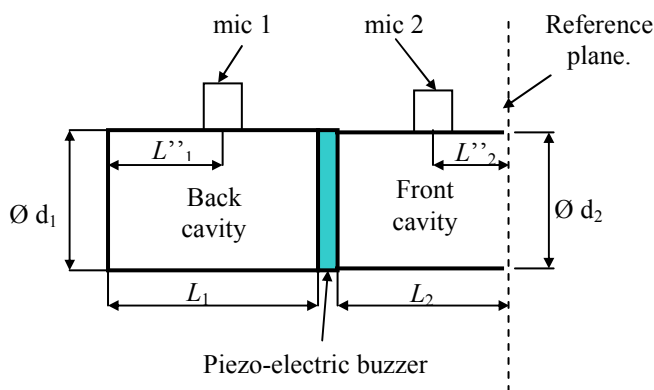

Fig.1 Schematic drawing of the impedance measurement setup and notations

In practice this equation (1) is only valid for low frequencies. Moreover, it is necessary to take the relative sensitivity of the two microphones into account, since the measured transfer function is $H_{12} = \frac{p_1 s_1}{p_2 s_2}$ with s_1, s_2 the

respective sensitivities of microphones 1 and 2. However, it is possible to calculate more precisely the expression of the impedance by taking into account the geometrical dimensions of the sensor:

$$H_{12} = K \frac{Z + \beta}{1 + \delta Z} \quad (2)$$

with $K = -j \frac{1}{Z_{c1}} \frac{s_2}{s_1} \frac{\sin(kL_1) \cos(kL_2'')}{\cos(kL_1'') \cos(kL_2)}$, $\beta = jZ_{c2} \tan(kL_2'')$

and $\delta = j \tan(kL_2) / Z_{c2}$.

Lengths L_1, L_2, L''_1 et L''_2 are dimensions related to the setup and to the position of the microphones as indicated on figure (1). $Z_{c1} = \frac{\rho c}{S_1}$ and $Z_{c2} = \frac{\rho c}{S_2}$ are the respective characteristic impedances of the front and back cavities ($S_1 = \pi d_1^2 / 4$ is the cross section of the back cavity with d_1 its diameter and the same for the front cavity).

It is important to notice that only the relative sensitivity of the sensors is unknown, geometrical quantities being accurately measured with a calibre. For this reason, the microphones (Panasonic electret microphones) were paired so that their relative sensitivity is close to unity.

3 Calibration

Calibration can be performed by using three known loads [1]. A calibration using three non resonant loads as in reference [2] has been performed showing a good matching between experimental and theoretical values of parameters β and δ . Then, a partial calibration with a single load is sufficient to obtain the sensitivity ratio of the microphones. Therefore, only the "infinite impedance" load is used for calibration. In that case the transfer function H_∞ is given by :

$$H_\infty = KZ_{c2} / \delta. \quad (3)$$

Results showing the measured transfer function and an analytical model show that an accuracy of +1% on the amplitude and +0.5° on the phase can be obtained (see figure(2)).

5 Comparison with the standard two microphones method

The measurement of various absorbing materials samples has been performed both with the standard two microphone method (BK setup [3]) and the present impedance measurement setup. The same sample holder (29mm diameter) is used for both measurements so that the material is being measured in the same conditions. Result for a 30mm long piece of foam is shown on figure (3).

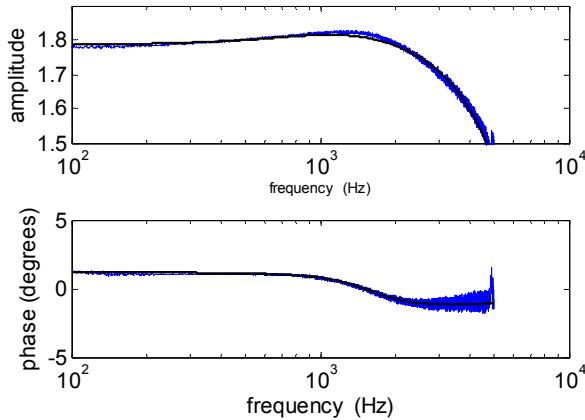

Fig.2 Calibration parameter KZ_{c2} / δ .

- Blue line: measurement.
- Black line: analytical model.

4 Application to absorption coefficient measurement

Calibration being done, the measured impedance can be deduced from the measured transfer function H_{12} as :

$$Z = \frac{H_{12} / K - \beta}{1 - \delta H_{12} / K} \quad (4)$$

For the measurement of absorbing materials, the sample is placed in the sample-holder of cross section S used for standard measurement with the two microphones technique. The reflection coefficient is then obtained from:

$$R = \frac{Z - Z_c}{Z + Z_c} \quad (5)$$

with $Z_c = \frac{\rho c}{S}$. From this reflection coefficient the absorption coefficient α can be deduced as:

$$\alpha = 1 - |R|^2. \quad (6)$$

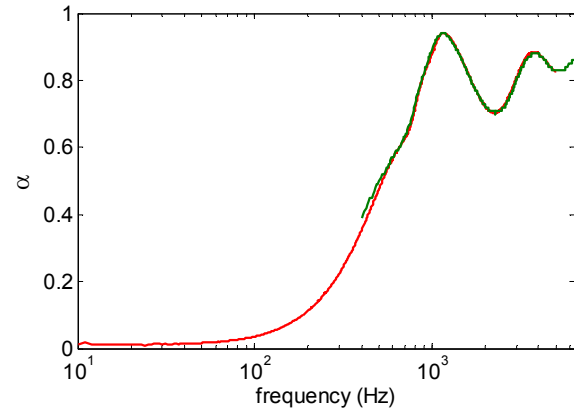

Fig.3 Measured absorption coefficient.

- Red line: the present impedance measurement setup (range 10-5000Hz).
- Green line: standard two-microphone impedance measurement tube (range 400-6400Hz).

It is reassuring to see that both measurement techniques lead to the same result in their common frequency range suggesting that both method are accurate. Only a small discrepancy is visible in the 400-600Hz frequency range.

6 Low frequency measurements

The big advantage of our setup is that it allows measurements of absorbing materials in the low frequency range (under 100Hz) which is not possible usually. As an example, the bulk modulus of the equivalent fluid at low frequency for the same sample as in figure (3) is plotted in figure (4). The bulk modulus χ is deduced from impedance Z by using the following expression

$$\chi = \operatorname{Re}(j\omega ZSL)^{-1} \quad (7)$$

Valid for $kL \ll 1$ with L the length of the sample.

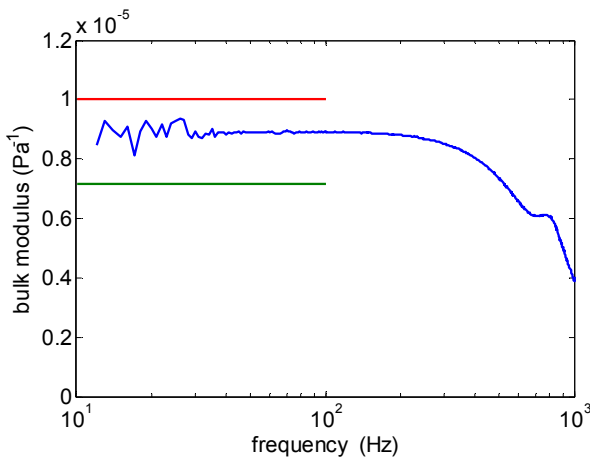

Fig.4 Bulk modulus of the equivalent fluid of a piece of foam.

- blue line: experiment (equation (7))
- green line: air (adiabatic model).
- red line: air (isothermal model)

Conclusion

Our measurement setup is shown to be able to perform measurements with the same accuracy as the standard two-microphone technique but on a wider frequency range (8 octaves instead of 4). However, the present setup is actually limited to frequencies under 5kHz. The frequency range can be extended by using slightly smaller cavities and the accuracy could be improved by using condenser microphones.

Acknowledgments

The authors want to acknowledge Eric Portier (CTTM) for the development of the software, Olivier Graton, Baudoin Gaulin (CTTM) and Nicolas Le Potier for their work on the impedance measurement setup.

References

- [1] J.-P. Dalmont "Acoustic impedance measurements Part I: a review", *J. Sound Vib.* **243** (3), 427-439 (2001).
- [2] P. Dickens, J. Smith, and J. Wolfe "Improved precision in measurements of acoustic impedance spectra using resonance-free calibration loads and controlled error distribution", *J. Acoust. Soc. Am.*, **121**(3), 1471-1481 (2007).
- [3] BRUEL & KJAER 1995 Product data sheet BP 1039-12 Two-microphone impedance measurement tube – Type 4206.